

4

3

↓

2

1

NOTES, UNLESS OTHERWISE SPECIFIED

- 1. UNSPECIFIED FILLET RADII .005-.010.
- 2. MATERIAL: AL BAR 6061-T651
- 3. THREADS PER ANSI B1.1.

REV	ZONE	DESCRIPTION	APPROVED	DATE
-		INITIAL RELEASE		

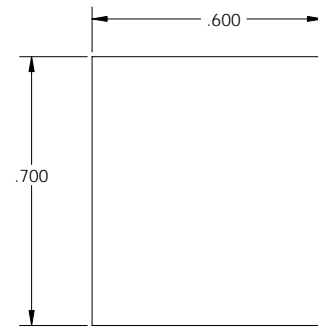
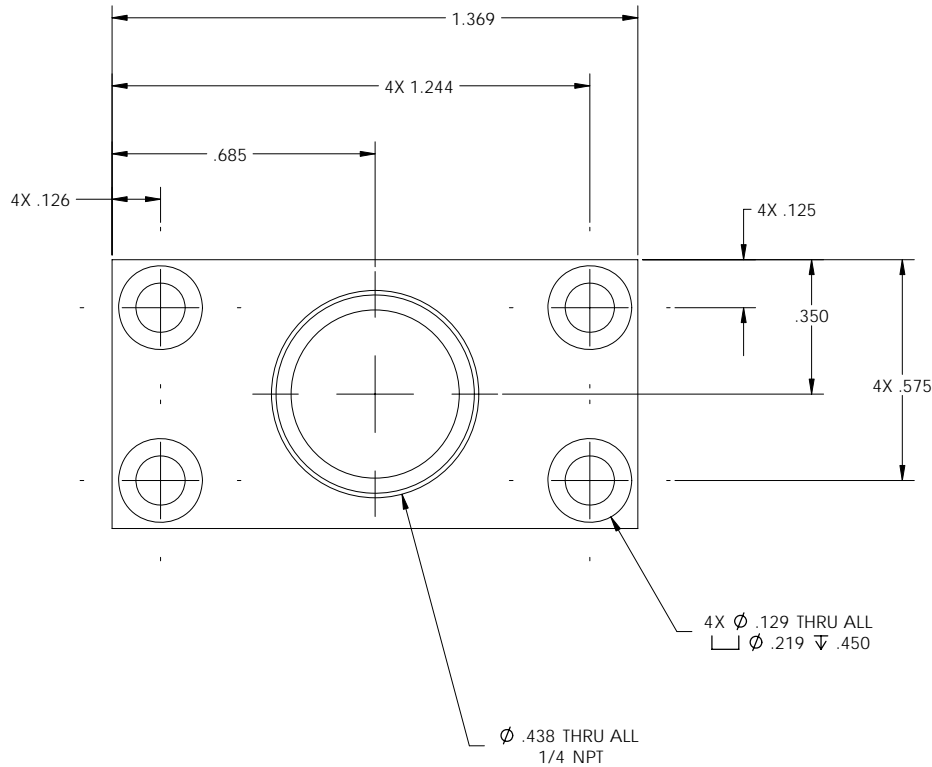
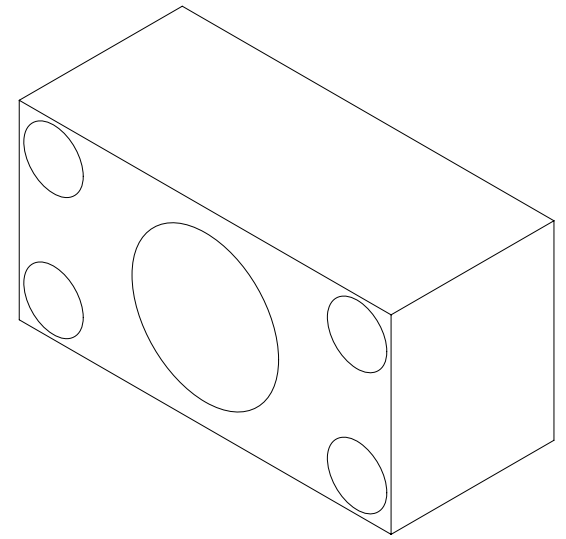

ALL DIMENSIONS ARE IN INCHES- INTERPRET DRAWING PER ASME Y14.5 -1994

TOLERANCES UNLESS OTHERWISE SPECIFIED:
 X.X ± .03 ∠ ± .5°
 X.XX ± .01
 X.XXX ± .005 125/

REMOVE ALL BURRS AND SHARP EDGES .005 R OR CHAMFER MAX

APPROVED	DATE
PREP BY D. ANDERSON	
CHECKED	
RESP ENG D. ANDERSON	
MFG ENG	
QUAL ENG	



BLOCK, INLET

SIZE	FSCM NO.	PART NO.	PART REV	DOC REV
C				02
SCALE	4:1	WT	0.04	SHEET 1 OF 1

◆ = (CRITICAL DIMENSION)

4

3

↑

2

1

D

D

C

C

B

B

A

A